



Fresh **Answers**
for today's bakery.

FROZEN DONUT PROCESSING
Thermoglaze 25 • Thermoglaze 50

Thermoglaze System

Belshaw's Thermoglaze system provides the method for thawing, heating and glazing pre-fried, frozen donuts and baked goods that bakers have been looking for.

The Thermoglaze system successfully addresses a common complaint with frozen donuts — stale taste and poor shelf-life after thawing. Frozen donuts that are reconstituted using the Thermoglaze system have greater moisture content and longer shelf-life than those thawed in air. In fact, donuts produced on the Thermoglaze system approach, and can surpass, the quality of fresh made donuts.

The Thermoglaze system consists of two components — the Thermolizer, for thawing frozen baked goods, and the Thermoglaze, for heating and glazing. Donuts can be held in the Thermolizer for up to five hours, allowing your bakery to supply hot, fresh-tasting donuts to your customers with little wait — or fuss.

The Thermoglaze system does not require a ventilation hood, does not utilize shortening, and improves glaze yield — reducing both set-up costs and operating costs.



Thermoglaze 50
with optional Thermolizer



Thermoglaze 25
(rear view)



Thermolizer TZ-6 (left)
TZ-17 (right)

Thermoglaze Standard Features

- One-switch operation.
- Unique conveyor design which greatly reduces donut handling.
- No ventilation hood or fire suppression system required.
- ETL Listed to UL Standards UL-197, NSF-4 and CSA C22.2 No 109. TG-25 is ETL listed to NSF-6

Thermolizer Standard Features

- Regulated moisture and temperature for maintenance of donut quality.
- TG-25 features an integrated Thermolizer unit
- TZ-6 (6 shelves) rolls under TG-50 to form a compact unit.
- TZ-17 (17 shelves) stands separately and is mobile.
- ETL listed to UL-197 & NSF-4

Thermolizer Options

- Auto-water feed (TZ-6 and TZ-17 only)
- Glazing screens for TG-50 system: 17" x 25" (Belshaw #SL200-4)
TZ-6 – 36 screens recommended
TZ-17 – 72 screens recommended
- Glazing screens for TG-25: 12.5" x 17" (Belshaw #TJ-0001)
36 screens recommended

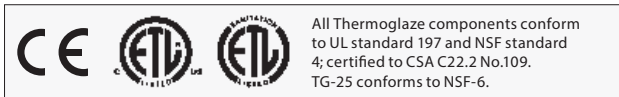

*PATENTS PENDING

TG-50

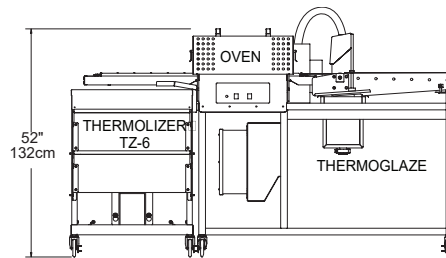
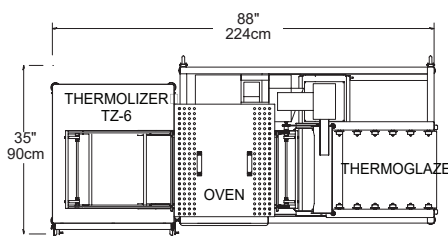

TG-25

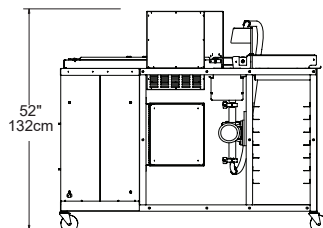
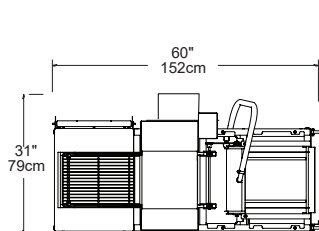

TZ-17

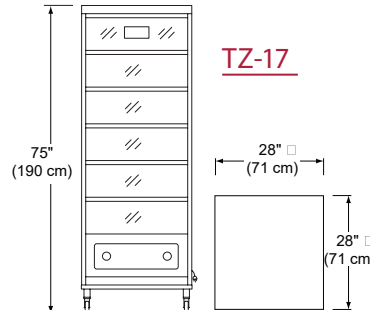

TG-25 PRODUCT FLOW SPECIFICATIONS

FLOW = THERMOLIZER → OVEN → GLAZER

The TG-25 can be specified with product flow in either direction. In addition, Thermolizer can be specified to operate either from the FRONT or BACK.

When purchasing specify TG-25 configuration as A, B, C or D as follows:

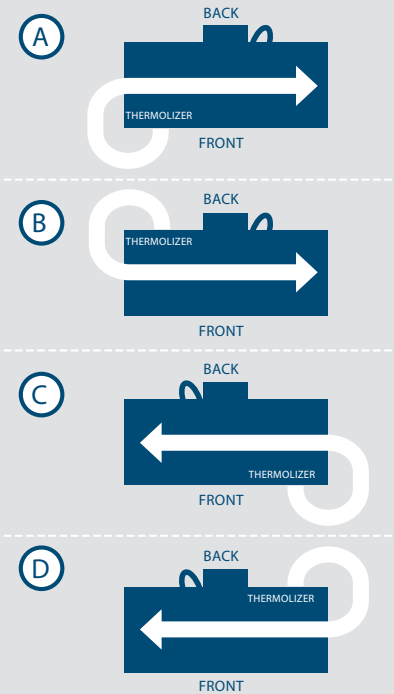

Dimensions And Power

MODEL	PRODUCTION CAPACITY	DIMENSIONS & WEIGHT (Shipping Class = 85)				POWER REQUIREMENTS		
		WIDTH	DEPTH	HEIGHT	SHIP WEIGHT	VOLTS	AMPS	KW
THERMOGLAZE (TG-25)	25 doz/hr	60in (152cm)	31in (79cm)	52in (132cm)	475 lbs (216 kg)	208/220/240V 60hz,1ph	38 A ²	7.5 KW
THERMOGLAZE (TG-50)	50 doz/hr	88in (214cm) ¹	35in (87cm)	52in (132cm)	650 lbs (295)	208/220/240V60hz,1ph	29 A ³	6.0 KW
THERMOLIZER (TZ-6)	50 doz/hr	29 in (74cm)	34 in (87cm)	38 in (97cm)	165 lbs (75 kg)	208/220/240V 60hz,1ph	11/13 A	2.4/3.1 KW
THERMOLIZER (TZ-17)	68 doz/hr	29 in (74cm)	35 in (89cm)	76 in (192cm)	300lbs (136 kg)	208/220/240V 60hz,1ph	20/19 A	4.2/4.6 KW

IMPORTANT:

- Includes TZ-6 Thermolizer as shown in drawing above. Separate space needed for TZ-17 Thermolizer if used.
- Includes integrated Thermolizer.
- Does not include Thermolizer. TZ-6 may be plugged into TG-50; to determine total current on TG-50 circuit, TZ-6 must be added to the TG-50.
- TG-50 and TG-25: plug type NEMA #6-50P. Cord length: 72in (1.8m).
TZ-6: plug type NEMA #6-20P. Cord length: 72in (1.8m). Plug inserts to TG-50.
TZ-17: plug type NEMA #6-30P. Cord: 72in (1.8m). Does not insert to TG-50.