

Product Line	THERMOGLAZE	Frozen Donut Processing	SPEC TG50/ 01-2013
Model	TG50		

THERMOGLAZE TG50

Thermoglaze is a system that thaws, heats, and glazes frozen donuts. The Thermoglaze system provides a method for preparing pre-fried frozen donuts, and other baked goods, with results that equal and often surpass the quality of freshly made product.

Thermoglaze can process all the varieties of frozen donuts currently available including ring donuts, fritters, long johns, cream and jam-filled donuts and many others. Thermoglaze is easy to learn, can be used in front of customers, and requires no ventilation hood.

The Thermoglaze TG50 processes approximately 50-75 dozen donuts per hour. Heating time and temperature can be modified to suit the product.

The Thermoglaze TG50 uses 17" x 25" (43 x 64 cm) glazing screens, Belshaw Part Nbr. SL-0004. Each screen holds 2 dozen donuts. 24 or more screens are recommended.

Frozen donuts (or similar product) are first thawed in a proofer at approximately 105°F (40°C). Donuts can be held in a proofer for up to five hours before processing in the TG50.

After thawing/holding in a proofer, the screens full of donuts are placed on the TG50's conveyor for heating and glazing. This takes less than 5 minutes.

Glaze is pumped up to a dispenser which coats each donut with a 1/8" thick curtain of glaze as they pass through. For iced donuts, the flow of glaze is turned off, and donuts can be iced on a Belshaw H&I-2 or H&I-4 icer.



TG50 (front view)



TG50 (rear view)



TG50 glazer in operation



Filled donuts after glazing on TG50

Product Line	THERMOGLAZE	SPEC TG50/01-2013
Model	TG50	

THERMOGLAZE TG50 STANDARD FEATURES

- Simple 2-switch operation (Oven and Glazer)
- Capacity 50-75 dozen donuts/hour
- No ventilation hood or fire suppression system normally required. (Verify with local authorities)
- Heavy duty glaze pump
- Speed and temperature adjustable inside control box
- Quiet operation
- Glaze pump can be switched on/off as required
- All stainless steel construction
- Easy to clean oven interior
- 2 Teflon handles supplied for picking up screens
- Spare gaskets kit
- 4" (25mm) casters, locking
- Lock-out feature to prevent machine starting while cleaning is in progress
- 24 to 60 screens are recommended depending on the amount of donuts produced

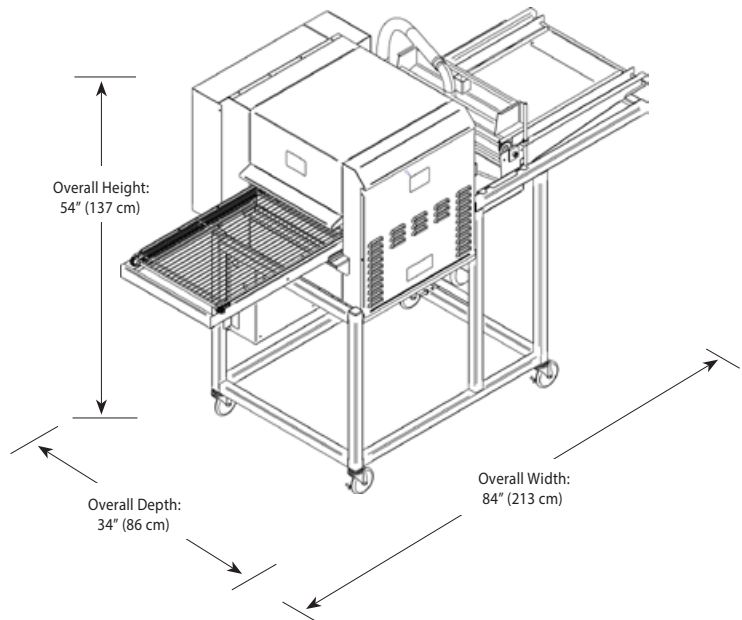

CERTIFICATIONS

- TG50 208V/60/1 is ETL certified to UL-197, CSA C22.2 and NSF-4
- TG50 models shipped to European Union conform to CE requirements, unless otherwise stated at time of purchase



SCREENS

- TG50 uses glazing screens 17" x 25" holding 24 donuts each, Part Number SL200-0004. At least 24 screens recommended. (Pictured below)



ELECTRICAL DATA

- Volts: 208 Volts, 60 Hertz, 1 phase
- Amps: 32.2A
- Kilowatts: 6.7 KW
- Plug: 360P6W (Consult factory at time of order)
- Cord: 72" (1.8m)
- Worldwide voltages available

SHIPPING DATA

- Shipped on pallet
- Width: 92" (185 cm)
- Depth: 39" (107 cm)
- Height: 58" (158 cm)
- Shipping weight: 630 lbs (295 kg)
- Freight class: 85
- Screen weight: 45 lbs/21 kg per dozen screens

OPTIONAL ACCESSORY: H&I-2 OR H&I-4 ICER



Water-warmed icing tables for applying icings to donuts warmed on the Thermoglaze system.

- H&I-2 Icer: Two 13" bowls
- H&I-4 Icer: Four 13" bowls
- H&I-2/4 spec sheet: <http://www.belshaw-adamatic.com/products/doughnut-icers/hi4-donut-icer.html>